

Chatillon® MT150 Series Mechanical Force Tester

Specification Sheet

SS-MT150-0210

February 2010

The CHATILLON®MT150 Series mechanical test stand is an easy-to-use solution for force measurement applications up to 150 lbf (660N) capacities. The test stand may be equipped with a quick-action lever or precision handwheel for controlling crosshead speed and travel. The MT150 test stand can be bench mounted, wall mounted or positioned horizontally. Vertical clearances are available from 750mm (29.5 inch) up to 1500mm (60 inch). Standard stroke is 6 inches (150 mm), although longer strokes can be accommodated as a special order.

The MT150 Series features an innovative design that maximizes working space and simplifies operation and maintenance. The single column design with 150mm (6 in) throat is ideal for large specimens. The removable platen is designed to accommodate metric and imperial threaded fixtures. Special gauge adapter make gauge alignment automatic. Options include a digital travel indicator, capable of displaying travel up to 0.01mm (0.0005 inch) and column ruler which is graduated in millimeters and inches.

The MT150 Series includes hook, compression plate, adapters and gauge mounting hardware.

Features

- Tensile, Compression, Peel & Flexural Testing
- Optional Column Heights
 - 500mm Standard
 - 1000mm Extended
 - 1500mm Ultra
- 6-inch Stroke
 - Longer Strokes Available as Special Order
- Compact, Lightweight, Benchtop Design
 - Table & Wall Mount Options
- Simple Operation
 - Lever Actuation
 - Handwheel Actuation
- Mounts to Chatillon DF Series Force Gauges
- 2 Year Warranty

Specifications

Load Capacity:	150 lbf, 660 N
Column Heights:	500mm Standard 1000mm Extended 1500mm Ultra
Stroke	6 inches (152mm) Longer Strokes Available
Travel Rates:	
Lever Actuator:	75mm per Revolution
Handwheel Actuator:	12mm per Revolution
Load Measurement:	Chatillon DF Gauges
Operating Temperature:	40° F to 110° F 5° C to 45° C
Instrument Weight:	20 lbs (9 kg)
Shipping Weight:	25 lbs (12 kg)



Shown: MT150L Series with optional Chatillon DFE Series digital force gauge and optional digital travel indicator.



Quality Assured.

AMETEK® | **Chatillon®**
Force Measurement

Ordering

MT150 Series

Order No. Description

BASE Model Number - 1st thru 6th Characters
 MT150L CHATILLON MT Series Mechanical Tester, Lever Actuated
 MT150H CHATILLON MT Series Mechanical Tester, Handwheel Actuated

Column Height - 7th Character

S Standard, 750 mm (29.5 in)
 E Extended, 1000mm (39.4 in)
 U Ultra, 1500 mm (60 in)

Force Gauge Mounting Kit - 8th Character

1 LG and DF Series Force Gauges
 2 DG Series Force Gauge
 X Not Required

Mounting Style - 9th Character

B Bench, Vertical Mounting
 H Bench, Horizontal and Wall Mounting

Options - 10th Character

1 Digital Travel Indicator
 2 Ruler Assembly (Imperial/Metric Graduations)
 X Not Required

Sample Order Number

CHATILLON MT150 Series (150 lbf, 660N), standard 750mm (29.5 in) travel with LG Series mounting kit. Vertical bench mounting style with lever actuator. Optional digital travel indicator supplied.

MT150L S 1 B 1
 (MT150LS5B1)

Optional Accessories

Part No.	Description
SPK-MT-Digital	Digital Travel Indicator
SPK-MT-Ruler	Ruler Assembly
SPK-MT-0001	Gauge Kit, DF, LG Series
SPK-MT-0002	Gauge Kit, DG, DFIS, DPPH Series
SPK-MT-0003	Gauge Kit, DFM Series
SPK-MT-0004	Gauge Kit, DFT Series
SPK-MT-Remote	Remote Load Cell Kit
SPK-MT-Wall-Horz	Wall Mounting Kit
SPK-MT-L150	Lever Actuator Assembly
SPK-MT-H150	Handwheel Actuator Assembly

Standard Accessories

Part No.	Description
SPK-FMG-012B	Hook
17012	Compression Plate, 3" Diameter
P-10020	Thread Adapter, 5/16-18 to #10-32
NC000714	Hex Key, 6mm
3157	Set Screw, #10-32 x 3/4"
13048	Coupling, 1/4-28 to 5/16-18
ADT/0115	5/8" Eye End Adapter

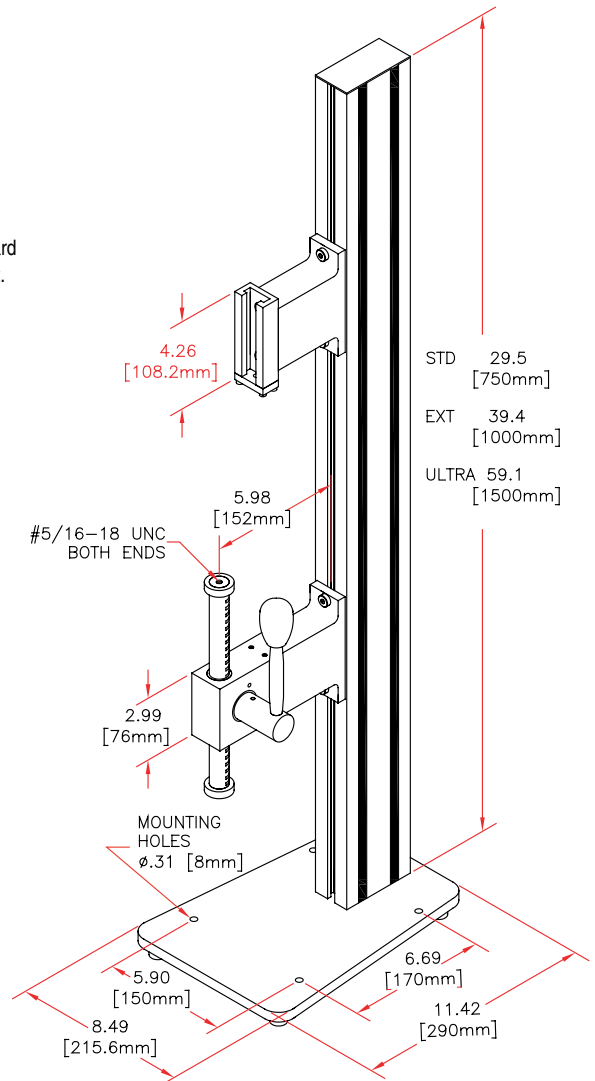

AMETEK

MEASUREMENT & CALIBRATION TECHNOLOGIES

For the authorized Chatillon Distributor or Manufacturer's Representative near you, go to www.chatillon.com

Americas
 AMETEK
 Measurement & Calibration
 Technologies
 8600 Somerset Drive
 Largo, Florida 33773
 United States of America
 Tel +1-727-536-7831
 Tel +1-800-527-9999
 Fax +1-727-539-6882
 Email chatillon.fl-lar@ametek.com

United Kingdom
 Lloyd Instruments Ltd.
 Steyning Way
 Bognor Regis
 West Sussex
 PO22 9ST
 United Kingdom
 Tel +44 (0) 1243 833 370
 Fax +44 (0) 1243 833 401
 Email uk-far.general@ametek.co.uk

France
 AMETEK S.A.S.
 Rond Point de l'Epine des Champs
 Buro Plus - Bat. D
 78990 Elancourt
 France
 Tel +33 (0)1 30 68 89 40
 Fax +33 (0)1 30 68 89 49
 Email general@lloyd-instruments.com

Germany
 AMETEK GmbH
 Rudolf-Diesel-Strasse 16
 D-40670 Meerbusch
 Germany
 Tel +49 (0)2159 9136-70
 Fax +49 (0)2159 9136-39
 Email info@ametek.de

Singapore
 AMETEK Singapore Pvt. Ltd.
 10 Ang Mo Kio Street 65
 #05-12 Techpoint
 Singapore 569059
 Tel +65-6484-2388
 Fax +65-6481-6588
 Email aspl@ametek.com.sg

Visit Us on the Worldwide Web at:
www.chatillon.com

© 2010 by AMETEK, Inc.

Information within this document is subject to change without notice.

ISO 9001/2000
 ISO/IEC17025
 Manufacturer