



TCM Series

Motorized Test Stands

100 lbf (500 N) & 350 lbf (1500 N)



2 Features

Key Features

► Easy Operation

A single key press to start the test and a return to zero function save time. A high maximum speed of 40 in/min (1016 mm/min) further reduces cycle time.

► Smart Functionalities

The large touch sensitive buttons feature haptic feedback that reduces the time taken to configure and run a test while reducing operator errors. Tests can be configured to pull to a set position or cycle between 2 positions. When combined with specific Chatillon force gauges, additional features such as driving to a load limit and recording break forces become available.

► Accurate Test Results

Combined with the Chatillon DF II Series force gauges the load accuracy exceeds 0.1% full scale. Advanced electronics enable set speed accuracy of < 0.1% of set speed value and data sampling rates up to 30 KHz.

► Large Working Area - Small Footprint

The compact TCM features a large throat depth enabling samples up to 7.96 in (200 mm) diameter to be tested, yet retains a compact footprint.

► Data Analysis and Integrity

Optional Chatillon ForceTest software allows viewing data in graphical form, data logging, result calculations, pdf report creation and data export. Download your free trial version now at www.ametektest.com.

Intuitive Effectiveness

The motorized TCM Series from Chatillon offers fast and effective force testing at an affordable price.

The TCM Series features a high frame stiffness, light weight bench top design suitable for both production and laboratory environments.

Force ranges of 100 lbf (500 N) and 350 lbf (1500 N) are available in both 16 in (406 mm) and extended 32 in (812 mm) travel versions.

Select from Chatillon's wide range of grips and fixtures to use the TCM Series for a wide variety of tests such as:

- Tension
- Compression
- Bending
- Peeling
- Adhesion
- Insertion and extraction



Force Capacity	
TCM100.....	100 lbf / 500 N
TCM350.....	350 lbf / 1500 N

Crosshead Travel	
TCM100.....	16 in / 406 mm
TCM100 Extended	32 in / 812 mm
TCM350.....	16 in / 406 mm
TCM350 Extended	32 in / 812 mm

The TCM Series offers you a flexible force measurement solution that matches your exact needs. This way you get a solution that lives up to your requirements, without costs for additional features you do not need. Should your needs change over time then it is easy to upgrade your TCM solution to fit your new requirements.

Base Solution

The TCM Series can be used in combination with Chatillon DFE or DFS Series force gauges. This way, if you already have a Chatillon force gauge available, you only need to acquire the TCM Series test stand to get started on your force testing, enjoying all of the

benefits that the TCM Series has to offer:

- ▶ Easy operation
- ▶ Haptic feedback buttons
- ▶ LED color display
- ▶ Set position or cycle between 2 positions



Extra Benefits

By adding a digital force gauge from the Chatillon DFE2 or DFS2 Series to your TCM Series test stand, additional features will become available enabling you to perform a more advanced, fast and easy force testing on your specimens.

- ▶ Drive to load limit
- ▶ Password protection
- ▶ Pass/Fail limits
- ▶ Average load
- ▶ Statistics
- ▶ Peak break force
- ▶ Contact close feature
- ▶ Access to ForceTest PC software



Extra features with a DFS3

By adding a Chatillon DFS3 series digital force gauge to your TCM test bench, additional features will be available allowing you to perform tests with greater ease, speed and better accuracy.:

- ▶ Displacement Display via Gauge
- ▶ Multiple Test Setups via gauge
- ▶ One press Start via TCM
- ▶ Stop on Limit (Break with DFS3)
- ▶ Optional ForceTest 3.0



4 A Modular System

With the ForceTest 3.0 software supplied with the DFS3, you will discover new features and unique performances for this range of machines. A simple and intuitive navigation allows you to create your test methods, visualize your curves directly, obtain results from a library of results and generate a PDF report and/or a CSV export.



Simple and Fast

With the Chatillon Forcetest software, you will improve your measurement solution based on TCM and you will transform your measurements into a simple and ripide process. By combining the flexible DFS3 series and the Forcetest software with the TCM series, you get the perfect solution for your tests.

Features Workflow

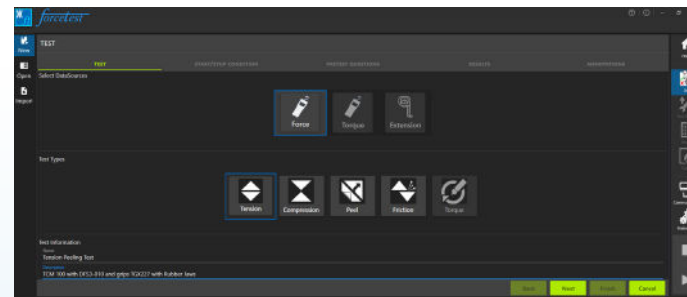

- ▶ A transparent data link from the TCM machine to your computer
- ▶ A recording of the configuration of the tests, a saving of time and traffic
- ▶ Export of measuring results and CSV rapport
 - ▶ Time/date stamped databases
 - ▶ A real time trace of the graphics and measure results.

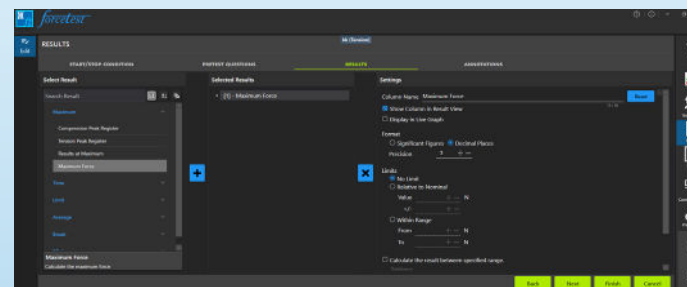

Analysis and Functions

- ▶ Configurable Test
- ▶ Test methods
- ▶ SQL data base
- ▶ Graphic annotations and values
- ▶ Limit pass/failures
- ▶ Statistics
- ▶ CSV export
- ▶ Customized PDF report
- ▶ Windows 10



5 Specifications

Technical Specifications

Force Capacity

TCM-100 100 lbf / 500 N
TCM-350 350 lbf / 1500 N

Speed Range

TCM-100 5.08 to 1016 mm/min /
0.2 to 40 in/min
TCM-350 5.08 to 1016 mm/min /
0.2 to 40 in/min

Speed Accuracy

0.1% of set speed value

Crosshead Travel

TCM100 16 in / 406 mm
TCM100 Extended 32 in / 812 mm
TCM350 16 in / 406 mm
TCM350 Extended 32 in / 812 mm

Supply Voltage

207-253 VAC at 50 Hz or 103.5-126.5 VAC at 60 Hz

Load Measurement

Chatillon DF Series gauge

Software

ForceTest

Weight

57 lbs / 26 kg - Standard height
69 lbs / 32 kg - Extended height

Shipping Weight

85 lbs / 39 kg - Standard height
132 lbs / 60 kg - Extended height

Throat Depth

3.98 in / 100 mm

Operating Temperature

50-104° F / 10-40° C

To ensure you receive an accurate, reliable instrument of the highest quality, Chatillon force measurement machines are designed and handcrafted at our factories in the United States in accordance to ISO 9001.

The TCM Series is CE certified and supported by our global service centres in accordance to ISO 17025.

Quality and integrity are part of our DNA, and we would like to help make it a part of yours as well.



Specifications & Ordering

Dimensions

A	Height	TCM100	29.7 in / 754 mm
		TCM100 Extended	45.7 in / 1161 mm
		TCM350	29.7 in / 754 mm
		TCM350 Extended	45.7 in / 1161 mm
B	Width	TCM100	10.8 in / 275 mm
		TCM350	10.8 in / 275 mm
C	Depth	TCM100	17 in / 431 mm
		TCM350	17 in / 431 mm
D	Base Height	TCM100	4.3 in / 108 mm
		TCM350	4.3 in / 108 mm

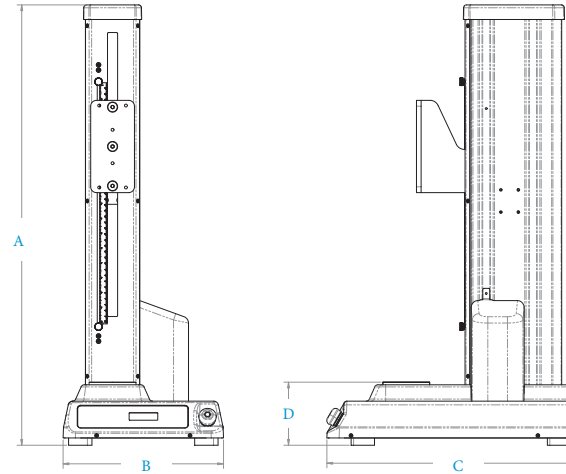

Ordering

Order Number	Description
	Model / Force
TCM100	TCM100, 100 lbf / 500 N
TCM350	TCM350, 350 lbf / 1500 N
	Crosshead Travel Height
S	Standard 16"
E	Extended 32"
	Power
115	115 VAC 60 Hz, US Power Cord
230	230 VAC 50 Hz, UK and EU Power Cord
230CNAU	230 VAC 50 Hz, China and Australia Power Cord
	Mounting
A	1/2-20F thread in base with 5/16 18M and 10/32M Base Adapter Coupling Kit
B	5/8" Eye End in Base and 5/8" Eye End Adapter Kit for DFE/DFS gauges
	Sample order number
TCM100 E 230 A	TCM100 Extended, 230 VAC 50 Hz UK and EU Power Cord and with a Base Adapter Coupling Kit



7 Accessories

Standard Accessories

Description	Part Number	TCM A Version	TCM B Version
1/2-20F Thread Base Plate	6344-01	●	●
1/2-20M to 5/16-18M Coupling	17162	●	
1/2-20M to 10M/32M Coupling	NC003238	●	
5/8" Eye Adapter to 1/2 20 Male Thread/ w / Pin & Locking Rings	SPK-TLC-003		●
5/8" Eye End Kit and Grip Pin for DFE/DFS Gauges	SPK-TCM-001		●
TCM USB to PC USB Cable, 3M (for Upgrades & PC Connection)	SPK-TCM-016	●	●
TCM to DFG3 Cable (Load Limit Communication to TCM)	SPK-TCM-034	●	●

TCM A Version

17162
Coupling
1/2-20M to 5/16-18M



NC003238
Coupling
1/2-20M to 10/32M



TCM B Version

SPK-TCM-001
Male anchoring kit 15.9 mm (5/8 ") for Force Gauges with pin.
Usable for Force Gauges with outputs #10-32 and 5/16-18.

SPK-TCM-003
Male anchor 15.9 mm (5/8 ") with locking rings ended up with a 1/2 20 m file tip (with a pin).

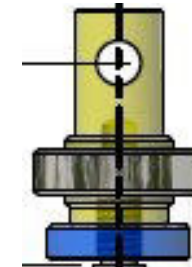

8 Accessories

Optional Accessories

Description	Part Number
Multi-Thread Plate Kit	SPK-TCM-005
T-Slot Table	SPK-TCM-011
Foot Switch	NC002910
Compression tray 3"	SPK-TCM-010
Splinter Shield	SPK-TCM-012
DFS Series Remote Load Cell Adapter Kit	SPK-TCM-014
TCM to DFG2 Cable (Load Limit Communication to TCM)	SPK-TCM-018

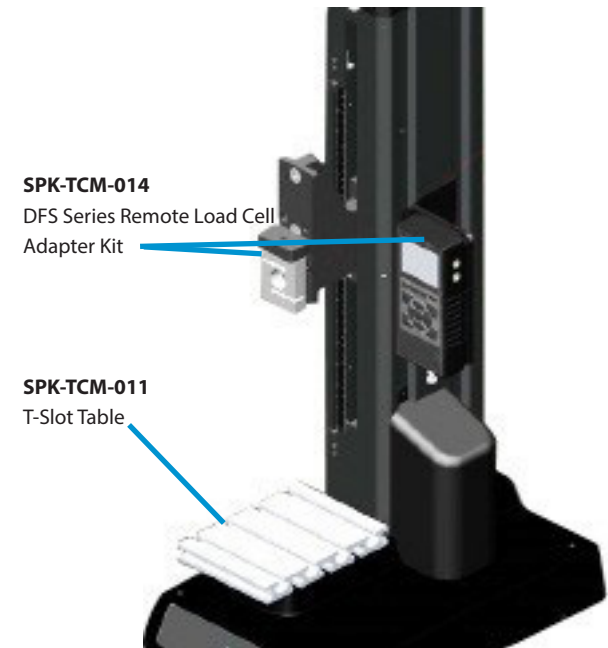

SPK-TCM-014
DFS Series Remote Load Cell
Adapter Kit

SPK-TCM-011
T-Slot Table

SPK-TCM-005
Multi-Thread Plate Kit

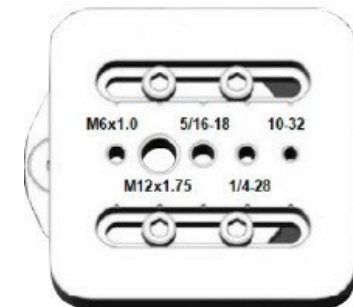

SPK-TCM-001
Male anchoring kit 5/8"



SPK-TCM-0010
Male anchoring kit 5/8"

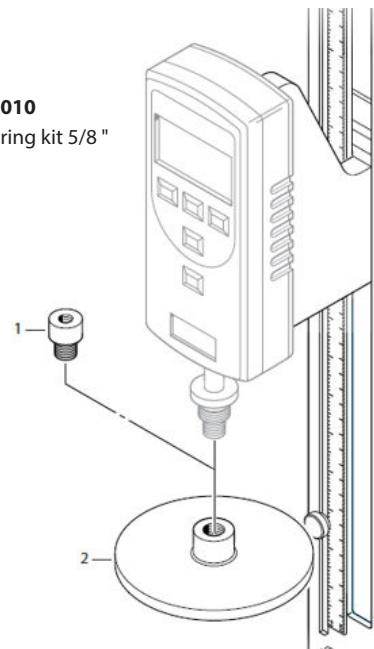

USA, Florida

Tel +1 (800) 527 9999
test.sales@ametek.com

India

Tel +91 22 2836 4750
test.sales@ametek.com

Singapore

Tel +65 6484 2388
test.sales@ametek.com

China, Shanghai

Tel +86 21 5886 5111
test.sales@ametek.com

China, Beijing

Tel +86 21 8526 2111-19
test.sales@ametek.com

United Kingdom

Tel +44 (0) 1243 833 370
stc.uk@ametek.com

France

Tel +33 (0) 30 68 89 40
general.lloyd-instruments@ametek.fr

Germany

Tel +49 (0) 2159 9136 510
info.mct-de@ametek.de

Denmark

Tel +45 4816 8000
test.sales@ametek.com

For detailed specifications
go to the Data Sheet at ametektest.com



No part of this document may be reproduced or modified in any form or by any means, electronic or mechanical, without express written permission from AMETEK STC.